

ASS. REC. BY: Taufiq

REF:

INC

ASSIGNMENT

From: _____ Date: _____
 Estimated Cost: _____
OD/TP/WS/TP RES/OD RES/EVA/INV/MV
 To Inspect Vehicle No: _____
 at Workshop m/s _____
 of _____
 Insured: _____
 Policy No. _____
 Claims No. _____
 Sum Insured: _____ Excess: _____
 (Client's Record)
 Make of Veh: _____

Veh No: SMD85729 Yr Regn: 20/6/1 Sep.
 Type: M.Car / M.Cycle / Bus / Van / Lorry / Taxi / Prime Mover /
 Truck / Trailer or _____
 Make: Myndor 140. c.c. 1685
 Colour: Yellow A/C: Insured / Std / NI / NA
 Sp. Reading: 736275 T/Radio: Insured / Std / NI / NA
 Eng/No: _____
 C/No: KMHLB414M G 093771
 Gen. Cond: Good / Fair / Poor / Burnt
 Steering: Inorder / Jammed / Leaked / Burnt or _____
 Brake: Inorder / Jammed / Leaked / Burnt or _____
 Modi: Nil / S/Rim / STD A/Rim or _____
 Tyre Size: F: 205/60R16
 R: 177

(Policy Condition)

| | |
|----------|----------|
| | |
| N/S | O/S |
| <u>X</u> | <u>X</u> |

Remark: The veh had commenced its repair at the time of inspection.

BS / DUN / EXNOVA / GY / FS / LIZA / MIC / OHTSU / PIR / SUMI / TOYO / YOKO or Westlake

Bal. or Market Value: _____
 IDAC Accident Rport: _____ Consistent?: Yes or No
 GIA / PR Seen: _____ Consistent?: Yes or No
 Est. Repairs: _____ days Res.: Yes or No
 Lum Sum: _____ % 3 Val.: Yes or No
 CA / REV / REP. / 24 HRS
 Date: _____ Person Contacted: Sumari
 Vehicle: IN / OUT

Front 6 mm Rear 6 mm
 R/Bal. 6 mm L/Bal. 6 mm
 D.O.A. _____ D.O.I. 1/4/23
 Survey held at Comfort Lodge
 Des. of Damages: Frt / Rear / O/S / N/S / U/C / Rooftop or _____
 The U/C / Chassis frame / Body Structure affected due to collision.

| Date / Time | Action / Instruction |
|-------------|----------------------|
| | |
| | |
| | |
| | |
| | |
| | |
| | |
| | |
| | |
| | |

Date/Time, File Pass to? : Preli. Report
 : Final Report

Days Of Repair: _____
 Resurvey No. of Trip: _____

| | |
|-----------------|--|
| SURVEY FEE: | |
| Transportation: | |
| S + RS. SI | |
| Photos | |
| Others | |
| TOTAL | |

1) Date/Time, File Return to? _____
 2) _____
 Rep. Format: _____
 Lump Sum / L.B. (\$) _____

Add Fee: : Site Insp (\$) _____
 : Interview (\$) _____
 : Tech. Invs (\$) _____
 : Weekend (\$) _____

COMFORTDELGRO ENGINEERING PTE LTD

REPAIR ESTIMATE

Income (Usuni)

Date: 11.04.2023

Time: 13:40:57

Page: 1

JM

COMPANY : THIRD PARTY'S CLAIMS (CAS)
 CUSTOMER: 7010070
 ADDRESS : CITYCAB PTE LTD
 383 SIN MING DRIVE
 SINGAPORE SINGAPORE 575717
 65551188

JOB NO : 305550944
 REGN NO : SHD8572Y
 MILEAGE : 0000000000
 MAKE : HYUNDAI
 MODEL : I-40
 DATE OF REGN : 15.09.2016
 DATE/TIME IN : 11.04.2023 10:30
 ACCIDENT DATE : 11.04.2023

JOB / PARTS DESCRIPTION

QTY IND UNIT-PRICE DISC% AMOUNT

PART REQUISITION

| | | | | | | | |
|------|-------------------|---------------------------|----|--------|-------|--------|-------|
| 0001 | 04-01-0103-0579-G | COVER ASSY-RR BUMPER# | 1 | 553.00 | 20.00 | 442.40 | fx |
| 0002 | 04-01-0101-0111-G | BUMPER COVER CLIP REAR | 10 | 22.00 | 20.00 | 17.60 | net - |
| 0003 | 04-01-0103-0739-G | ABSORBER-RR BUMPER ENERGY | 1 | 119.50 | 20.00 | 95.60 | ? |
| 0004 | 04-01-0103-0740-G | BEAM-RR BUMPER# | 1 | 428.40 | 20.00 | 342.72 | ? |
| 0005 | 04-01-0103-0738-G | COVER-RR BUMPER LWR# | 1 | 228.00 | 20.00 | 182.40 | cut - |

SUB-TOTAL : 1,080.72

JOB NATURE

| | | | | | | | |
|------|----|-----------------------------|--|--------|--|-------|----|
| 0000 | L | PANEL BEAT | | 300.00 | | 280. | |
| 0001 | SP | SPRAYPAINT CHARGE | | 300.00 | | 250 | |
| 0002 | L | REMOVE/REFIX REVERSE SENSOR | | | | 50.00 | 30 |

SUB-TOTAL : 650.00

Tanji 97495789
 WR u 14/25 R 4pm
 2 days
 L/S Resurvey after repair
 tanji C/M auto.com

LKK Auto Consultants hence notify the Repairer of the following:

- To resurvey before/after spray painting
- To display damaged part(s) during resurvey
- Parts prices are subject to confirmation
- Third party survey is on a "Without Prejudice" basis
- No illegal modification(s) is allowed
- Supplementary item(s) must be resurveyed and is subject to final approval from Insurance Company

Acknowledged by Repairer

Signature:

Workshops

Date/Time: 11.04.2023 13:36

Page : 1

am: ARC Repair TP(CFSO)1

JOB CARD Sales Order: 5892649

JC NO305550944

| | | |
|---|--|---|
| OMER CITYCAB PTE LTD S 7010070 OMER NO ESS 383 SIN MING DRIVE Singapore SINGAPORE 575717 (R) 65551188 (O) (P) UNIT CARD NO. | REGN NO: SHD8572Y | MILEAGE |
| | MAKE: HYUNDAI | FUEL E.....1/2.....F |
| | MODEL I-40 | DATE/TIME IN 11.04.2023 10:30 |
| | YR OF MANU. 15.09.2016 | TARGET DATE |
| | CHASSIS CODE KMHLB41UMGU093741 | COMPLETION DATE/TIME: |

Incident Date: 11.04.2023
 Accurrence: 3P.11.04.23

JOB DESCRIPTION

NO LABOR CODE DESCRIPTION

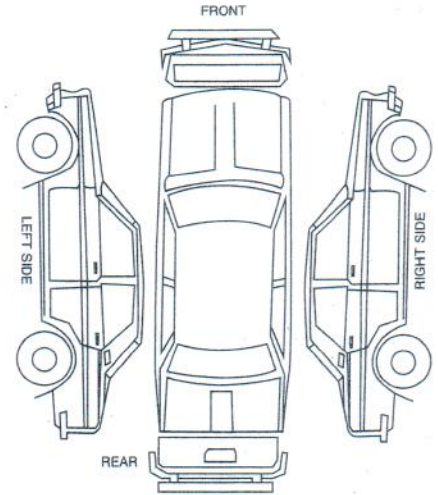

RECEIVED & PASSED OUT BY: _____

 SERVICE ADVISOR

 CUSTOMER'S SIGNATURE

Confirmation Slip
 No.: **SHD8572Y** **JU INCOME**

Exit Pass
 Vehicle No.: **SHD8572Y**

 Service Advisor Signature/Date

 Name of Service Advisor Date

Returned to Service Reception upon collection

To be kept by Security Guard