

SINGAPORE ACCIDENT STATEMENT

IMPORTANT NOTICE

1. Please report correctly the details of the accident to speed up the claims process.
2. This Form must be completed by the Policyholder and/or the Authorised Driver.
3. Information provided must be as truthful and accurate as possible. Any wilful misrepresentation or withholding of material facts may allow insurance companies to repudiate policy liability.
4. The issue and acceptance of this Form by insurance companies is not an admission of policy liability on the part of the insurance companies.
5. **Any false reporting may be referred to the Police for investigation.**
6. This report will be forwarded by the insurers of the GIA Records Management Centre established by the General Insurance Association of Singapore (GIA) for archiving and that copies of this report will, for a fee, be made available upon application by interested parties.
7. By the lodgement of this report to the insurers, you hereby consent to the archiving of this report at the centre and to copies of the report being made available aforesaid.

ACCIDENT STATEMENT

Date Of Report	17/02/2020 16:40
Date Of Accident	14/02/2020 17:20
Exact Location Of Accident	AYE TOWARD MCE LAMP POST 642F
Country/State of Loss	SINGAPORE

DETAILS OF OWN VEHICLE

Vehicle Registration Number	GBJ8605B
Insured/Policyholder	
Name Of Registered Owner	WORKZHOUSE PTE LTD
Co Reg No	2XXXXX138N
Email Address	NOEMAIL
Mobile Phone No	
Alternative Phone No	OFFICE-88932152

Vehicle Particulars

Manufacturer	NISSAN
Model	NV200-1.5 (A)
Exact Purpose for which vehicle was being used at time of accident	
Are you claiming under your own insurance policy for repair to your vehicle?	NO
If No, Please state action to be taken	THIRD PARTY
Vehicle Category	COMMERCIAL VEHICLE

Insurance Company

Name of Insurance Company	NTUC INCOME INSURANCE CO-OPERATIVE LTD
Type Of Coverage	COMPREHENSIVE
Fleet Policy	NO
Policy Number	5112701304
Cover Note Number	

Driver

Name of Driver	LIN ZHI GAO
NRIC No	SXXXX987J
Date Of Birth	30/08/1994
Occupation	OUTDOOR
Date Of Driving Pass	11/03/2014
Driving Experience	5 YEARS AND 11 MONTHS
Gender	MALE
Mobile Number	(LOCAL) +65-91117560
Fax Number	
Contact Number	
EEmail Address	NOEMAIL

Address	58A, LORONG MARZUKI 5
Postcode	417144
Was driver an employee of the Insured's Company	NO
If No, Relationship of the Driver with the Insured	FRIEND
Vehicle Registration Number of Driver's Own Vehicle	-
	-
	-
Insurance Company of Driver's Own Vehicle	-
	-
	-

General Information of the Accident

Type Of Accident	CHAIN COLLISION
Weather Conditions	CLEAR
Road Surface	DRY

Other Information

Was any foreign vehicle involved in this accident?	NO
Number of vehicles (including own vehicle) involved in the accident	4
Was any body injured in the Accident?	NO
Was any injured conveyed to hospital by ambulance?	NO
Was any other material or property damaged?	YES
I have been approached by unknown person(s) soliciting/offering accident claims assistance.	NO
Number of Passengers (Including Driver)	2
Passenger 1	NAME: : PASSENGER
	GENDER: : FEMALE

Details of Police Action

Was the accident reported to the police?	NO
If Yes, Please state which Police Station	
Was notice of intended Prosecution given?	NO
If Yes, against whom?	

Circumstances of Accident

REFER TO SKETCH PLAN

Attachment(s)

Are accident photos available for attachment?	YES
Was there any video captured by Car Camera?	NO
Was there any audio recorded?	NO

DETAILS OF OTHER VEHICLE PROPERTY 1

Vehicle Registration Number	SLW2221C
Vehicle Make/Model/Colour	
Details Of Properties	
Vehicle Category	PRIVATE CAR
Name of Driver	
NRIC/Passport Number	
Contact Number	
Address	
Postcode	
Insurance Company Name	
Nature Of Damage	
No. Of Passenger (Including Driver)	

DETAILS OF OTHER VEHICLE PROPERTY 2

Vehicle Registration Number SMM1490P
Vehicle Make/Model/Colour
Details Of Properties
Vehicle Category PRIVATE CAR
Name of Driver
NRIC/Passport Number
Contact Number
Address
Postcode
Insurance Company Name
Nature Of Damage
No. Of Passenger (Including Driver)

DETAILS OF OTHER VEHICLE PROPERTY 3

Vehicle Registration Number SBL6226P
Vehicle Make/Model/Colour
Details Of Properties
Vehicle Category PRIVATE CAR
Name of Driver
NRIC/Passport Number
Contact Number
Address
Postcode
Insurance Company Name
Nature Of Damage
No. Of Passenger (Including Driver)

Accident Sketch Plan

SKETCH PLAN

IMPORTANT NOTICE

1. Please report **correctly** the details of the accident to speed up the claims process.
2. This Form must be **completed by the Policyholder and/or the Authorised Driver**.
3. Information provided must be as **truthful and accurate as possible**. Any wilful misrepresentation or withholding of material facts may allow insurance companies to **repudiate policy liability**.
4. The issue and acceptance of this Form by insurance companies is not an admission of policy liability on the part of the insurance companies.
5. **Any false reporting may be referred to the Police for investigation.**
6. The report will be forwarded by the insurers of the GIA Records Management Centre established by the General Insurance Association of Singapore (GIA) for archiving and that copies of this report will for a fee be made available upon application by interested parties.
7. By the lodgment of this report to the insurers, you hereby consent to the archiving of this report at the centre and to copies of the report being made available aforesaid.
8. **Consent under the Personal Data Protection Act (PDPA)**

I understand, acknowledge, agree and consent that:

- (a) My Insurer, my workshop and the General Insurance Association of Singapore ("GIA") may/are permitted to collect, use, disclose and/or process my personal data/personal information set out in this [form] and any other personal information provided by me or possessed by my insurer (collectively the "Personal Information") and disclose and transfer such Personal Information to all insurer(s) who have insured vehicle(s) involved in this accident (all insurer(s) who have insured vehicle(s) involved in this accident shall be collectively referred to as the "Insurers"), the Insurers' lawyers/law firms, the Monetary Authority of Singapore and any relevant government agency/authority (such as the police), for the purpose(s) of:
- (i) processing, handling and/or dealing with my claims including the settlement of the claims and any necessary investigations relating to the claims;
 - (ii) investigating the accident and/or my claims;
 - (iii) carrying out and/or dealing with my instructions or responding to any enquiries by me;
 - (iv) administering my claims (including the mailing of correspondence, statements, invoices, reports or notices to me, which could involve disclosure of certain personal data about me to bring about delivery of the same as well as on the external cover of envelopes/mail packages); and/or
 - (v) complying with applicable law in administering, processing, handling and/or dealing with my claims (collectively the "Purposes")
- (b) all insurer(s) who have insured vehicle(s) involved in this accident and the Insurers' lawyers/law firms, may/are permitted to collect, use, disclose and/or process my Personal Information for one or more of the above Purposes; and
- (c) my Personal Information may/can be disclosed by any of the Insurers and/or GIA to their third party service providers or agents (including their lawyers/law firms), which may be sited outside of Singapore, for one or more of the above Purposes.
- (d) my Personal Information will also be collected and used to compile claims history for the purpose of fraud detection, investigation and management in present and all future claims.
- (e) the information so collected under (d) above may be shared / disclosed:
- (i) to all insurers and/or any other third parties that assist in evaluating, investigating, controlling or managing fraud, regulators, law enforcement and government agencies as reasonably required for the purposes stated, or
 - (ii) for complying with requirements under any regulations, laws or court orders.



Policyholder's Signature
Date & Time:

[Signature]

Driver's Signature
(If driver is not the policyholder)
Date & Time:

[Signature]

CITY AUTO PTE LTD
Blk B Sin Ming Road
#01-56/60/62 Sin Ming Ind Est
Singapore 570643
Tel: 6453 1235 Fax: 6453 7944
(Claims Section)

Reporting Centre Personnel's Signature
Name:
NRIC/TIN No.:

Accident Sketch Plan

SKETCH PLAN

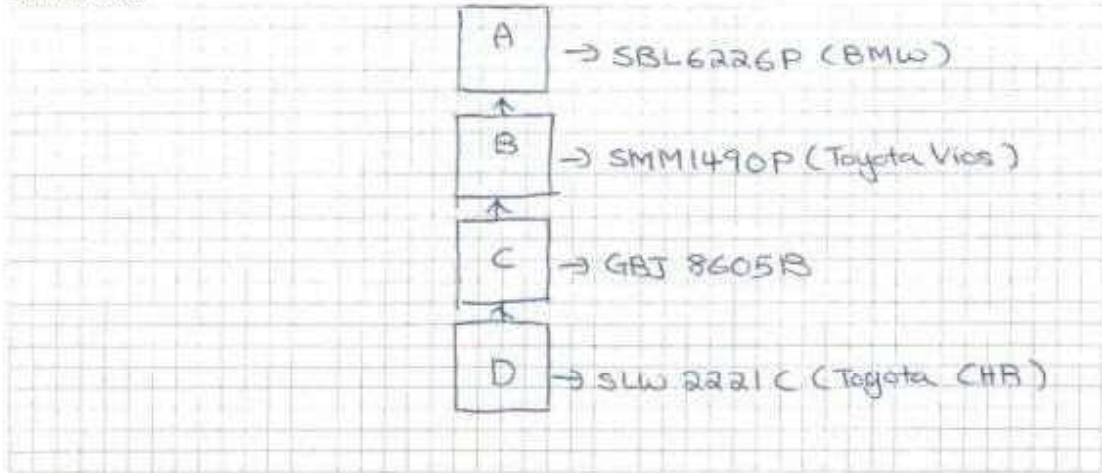

DESCRIBE CIRCUMSTANCES OF THE ACCIDENT

~~Vehicle~~
 Car B suddenly brake, I manage to brake on time. Car D from my rear hit onto my rear and due to impact & push my car to hit onto Car B. When I come down, I notice there is Car A involve in it.

DECLARATION

I/We declare the foregoing particulars are true in every respect.

 Policyholder's Signature
 Date & Time:

 Driver's Signature
 (If driver is not the policyholder)
 Date & Time:

CITY AUTO PTE LTD
 8A 8 Sin Ming Road
 #01-58/59/62 Sin Ming Ind Est
 Singapore 575643
 Tel: 6453 1235 Fax: 6453 7944
 (Claims Section)

Reporting Centre Personnel's Signature
 Name:
 NRIC/FIN No.: