

PREMIER AUTOMOTIVE SERVICES PTE LTD

23 CHANGI SOUTH AVE 2 #01-02
SINGAPORE 486443
TEL:65446671 FAX:62141511
CO. REG:200707743D GST REG:200707743D

Our Ref: SHC6028X/SR

WITHOUT PREJUDICE

13 March 2019

(By Email Only)

Attn: The Motor Claims Department

Lonpac Insurance Bhd
300 Beach Road #17-04/07
The Concourse
Singapore 199555

Dear Sir/Madam

**ACCIDENT INVOLVING SHC6028X AND GBH6175Z ALONG KALLANG
BAHRU ON 01.02.2019**

We have been authorized by Premier Taxis Pte Ltd, the owner of Taxi vehicle number: SHC6028X, to claim against the party/parties responsible for the damages arising from the above-mentioned accident.

Our records show that you are the insurers of vehicle number: GBH6175Z at the material time of the accident with the driver of our client's vehicle, Mr. Tan Kheng Chye.

As a result of the accident caused by your Insured Driver's negligent driving and/or management of your insured's Vehicle Number: GBH6175Z, our client's vehicle was damaged and we have been put to loss and damage as follows:

(1) Cost of repair (GST included)	\$ 888.10
(2) Loss of Rental – 3 Days @\$102.72 per day	\$ 308.16
(3) Loss of Income – 3 Days @\$100.00per day	\$ 300.00
(4) GIA Search fee	\$ 2.00
	<u>\$ 1,498.26</u>

A copy of each of the following supporting documents is enclosed:

- 1) GIA report & sketch plan of SHC6028X
- 2) Driver's I/C and Driving Licence
- 3) Final Repair bill
- 4) Vehicle Registration card, Certificate of Insurance, Certification Letter
- 5) Check In/Out Voucher
- 6) GIA search
- 7) Scene video

PREMIER AUTOMOTIVE SERVICES PTE LTD

23 CHANGI SOUTH AVE 2 #01-02

SINGAPORE 486443

TEL:65446671 FAX:62141511

CO. REG:200707743D GST REG:200707743D

Our Ref: SHC6028X/SR

We would appreciate if you could look into the subject matter and let us have your favorable offer within 14 days. If you are agreeable to the settlement of the above said claims, please forward us your discharge voucher as for our client's signature and payment made to "Premier Automotive Services Pte Ltd".

Please note that if we do not hear from you within the stipulated 14 days, we will have no alternative but to appoint our solicitor to act on our behalf to commence proceedings against you without further notice to you.

Yours faithfully,



Claims Department – Shafawati Md Rabu

Email: shafawati.rabu@premiertaxi.com

DID: 64100946

NB: We encourage all parties to liaise with us via email to expedite all matters

PS: Please quote our reference no when replying

c.c. Client – Premier Taxis Pte Ltd

SINGAPORE ACCIDENT STATEMENT

IMPORTANT NOTICE

1. Please report correctly the details of the accident to speed up the claims process.
2. This Form must be completed by the Policyholder and/or the Authorised Driver.
3. Information provided must be as truthful and accurate as possible. Any wilful misrepresentation or withholding of material facts may allow insurance companies to repudiate policy liability.
4. The issue and acceptance of this Form by insurance companies is not an admission of policy liability on the part of the insurance companies.
5. Any false reporting may be referred to the Police for investigation.
6. This report will be forwarded by the insurers of the GIA Records Management Centre established by the General Insurance Association of Singapore (GIA) for archiving and that copies of this report will, for a fee, be made available upon application by interested parties.
7. By the lodgement of this report to the insurers, you hereby consent to the archiving of this report at the centre and to copies of the report being made available aforesaid.

ACCIDENT STATEMENT

Date Of Report	01/02/2019 14:37
Date Of Accident	01/02/2019 13:35
Exact Location Of Accident	KALLANG BAHRU
Country/State of Loss	SINGAPORE

DETAILS OF OWN VEHICLE

Vehicle Registration Number	SHC6028X
Insured/Policyholder	
Name Of Registered Owner	PREMIER TAXIS PTE LTD
Co Reg No	200304975H
Email Address	NOEMAIL
Mobile Phone No	
Alternative Phone No	OFFICE-62148880

Vehicle Particulars

Manufacturer	KIA
Model	OPTIMA-1.7 D (A)
Exact Purpose for which vehicle was being used at time of accident	HIRED & REWARDS
Are you claiming under your own insurance policy for repair to your vehicle?	NO
If No, Please state action to be taken	THIRD PARTY
Vehicle Category	TAXI

Insurance Company

Name of Insurance Company	NTUC INCOME INSURANCE CO-OPERATIVE LTD
Type Of Coverage	THIRD PARTY
Fleet Policy	YES
Policy Number	5095103893
Cover Note Number	

Driver

Name of Driver	TAN KHENG CHYE
NRIC No	S1289447C
Date Of Birth	26/02/1958
Occupation	OUTDOOR
Date Of Driving Pass	28/07/1977
Driving Experience	41 YEARS AND 6 MONTHS
Gender	MALE
Mobile Number	(LOCAL) +65-91472698
Fax Number	
Contact Number	
EMail Address	NOEMAIL

Address BLOCK 493D TAMPINES STREET 43
#08-324

Postcode 1852

Was driver an employee of the Insured's Company NO

If No, Relationship of the Driver with the Insured OTHER - HIRER

Vehicle Registration Number of Driver's Own Vehicle -
-
-

Insurance Company of Driver's Own Vehicle -
-
-

General Information of the Accident

Type Of Accident SIDE SWIPE

Weather Conditions CLEAR

Road Surface DRY

Other Information

Was any foreign vehicle involved in this accident? NO

Number of vehicles (including own vehicle) involved in the accident 2

Was any body injured in the Accident? NO

Was any injured conveyed to hospital by ambulance? NO

Was any other material or property damaged? YES

I have been approached by unknown person(s) soliciting/offering accident claims assistance. YES

Number of Passengers (Including Driver) 5

Passenger 1 NAME: : UNKNOWN
GENDER: : MALE

Passenger 2 NAME: : UNKNOWN
GENDER: : MALE

Passenger 3 NAME: : UNKNOWN
GENDER: : MALE

Passenger 4 NAME: : UNKNOWN
GENDER: : MALE

Details of Police Action

Was the accident reported to the police? NO

If Yes, Please state which Police Station

Was notice of intended Prosecution given? NO

If Yes, against whom?

Circumstances of Accident

VEH A: 4 PASSENGERS VEH B: NOT SURE

Attachment(s)

Are accident photos available for attachment? YES

Was there any video captured by Car Camera? NO

Was there any audio recorded? NO

DETAILS OF OTHER VEHICLE PROPERTY 1

Vehicle Registration Number GBH6175Z

Vehicle Make/Model/Colour VAN

Details Of Properties

Vehicle Category

COMMERCIAL VEHICLE

Name of Driver

NRIC/Passport Number

Contact Number

Address

Postcode

Insurance Company Name

Nature Of Damage

No. Of Passenger (Including Driver)



SKETCH PLAN

IMPORTANT NOTICE

1. Please report correctly the details of the accident to speed up the claims process.
2. This Form must be completed by the Policyholder and/or the Authorised Driver.
3. Information provided must be as truthful and accurate as possible. Any wilful misrepresentation or withholding of material facts may allow insurance companies to repudiate policy liability.
4. The issue and acceptance of this Form by insurance companies is not an admission of policy liability on the part of the insurance companies.
5. Any false reporting may be referred to the Police for investigation.
6. The report will be forwarded by the insurers of the GIA Records Management Centre established by the General Insurance Association of Singapore (GIA) for archiving and that copies of this report will for a fee be made available upon application by interested parties.
7. By the lodgment of this report to the insurers, you hereby consent to the archiving of this report at the centre and to copies of the report being made available aforesaid.
8. **Consent under the Personal Data Protection Act (PDPA)**

I understand, acknowledge, agree and consent that:

- (a) My insurer, my workshop and the General Insurance Association of Singapore ("GIA") may/are permitted to collect, use, disclose and/or process my personal data/personal information set out in this [form] and any other personal information provided by me or possessed by my insurer (collectively the "Personal Information") and disclose and transfer such Personal Information to all insurer(s) who have insured vehicle(s) involved in this accident (all insurer(s) who have insured vehicle(s) involved in this accident shall be collectively referred to as the "Insurers"), the Insurers' lawyers/law firms, the Monetary Authority of Singapore and any relevant government agency/authority (such as the police), for the purpose(s) of :
 - (i) processing, handling and/or dealing with my claims including the settlement of the claims and any necessary investigations relating to the claims;
 - (ii) investigating the accident and/or my claims;
 - (iii) carrying out and/or dealing with my instructions or responding to any enquiries by me;
 - (iv) administering my claims (including the mailing of correspondence, statements, invoices, reports or notices to me, which could involve disclosure of certain personal data about me to bring about delivery of the same as well as on the external cover of envelopes/mail packages); and/or
 - (v) complying with applicable law in administering, processing, handling and/or dealing with my claims.(collectively the "Purposes")
- (b) all insurer(s) who have insured vehicle(s) involved in this accident and the Insurers' lawyers/law firms, may/are permitted to collect, use, disclose and/or process my Personal Information for one or more of the above Purposes; and
- (c) my Personal Information may/can be disclosed by any of the Insurers and/or GIA to their third party service providers or agents(including their lawyers/law firms), which may be sited outside of Singapore, for one or more of the above Purposes.
- (d) my Personal Information will also be collected and used to compile claims history for the purpose of fraud detection, investigation and management in present and all future claims.
- (e) the information so collected under (d) above may be shared / disclosed:
 - (i) to all insurers and/or any other third parties that assist in evaluating, investigating, controlling or managing fraud, regulators, law enforcement and government agencies as reasonably required for the purposes stated, or
 - (ii) for complying with requirements under any regulations, laws or court orders.



Policyholder's Signature
Date & Time:

[Signature] S1289447/C

Driver's Signature
(If driver is not the policyholder)
Date & Time:

[Signature]

Reporting Centre Personnel's Signature
Name:
NRIC/FIN No.:

SKETCH PLAN

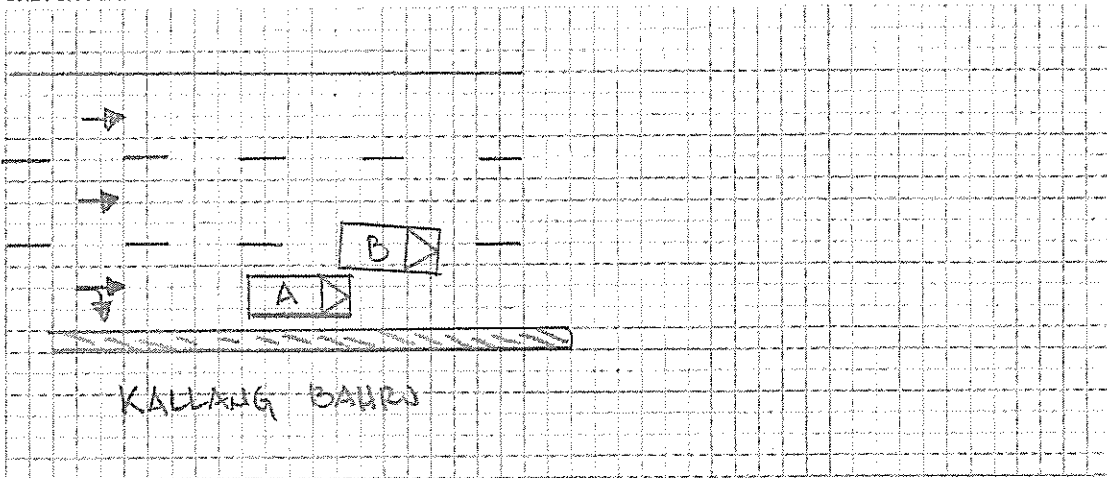



DESCRIBE CIRCUMSTANCES OF THE ACCIDENT

A: SHC 6028 X
B: GBH 6175 Z

DECLARATION

I/We declare the foregoing particulars are true in every respect.

Policyholder's Signature
Date & Time:

Driver's Signature
(If driver is not the policyholder)
Date & Time:

S1289447/C
Reporting Centre Personnel's Signature
Name:
NRIC/FIN No.:

Describe Circumstance of the Accident.

ON 01/02/2019 @ 1230 HRS, I WAS DRIVING MY TAXI (SHC 6028 X), TRAVELLING ALONG KALLANG BAHRU TOWARDS KALLANG AVENUE WITH 4 PASSENGERS ONBOARD, IN EXTREME RIGHT LANE.

WHILE MOVING, SUDDENLY VEHICLE B (GBH 6175 Z - RENAULT) WHICH WAS FROM MIDDLE LANE FAILED TO OBSERVE FOR CLEARANCE FROM MY ROUTE AND HAD ENCROACHED ONTO MY PATH ABRUPTLY.

AS SUCH, THE RIGHT PORTION OF VEHICLE B COLLIDED ONTO THE LEFT FRONT OF MY TAXI.

DUE TO THE IMPACT, MY TAXI HAD DAMAGES ON THE LEFT FRONT PORTION & VEHICLE B HAS DAMAGES ON THE RIGHT REAR PORTION.

NO INJURY INVOLVED.

FOUR PASSENGERS ONBOARD MY TAXI AND VEHICLE B NOT SURE.

DAMAGES FOUND ON VEHICLE A & VEHICLE B

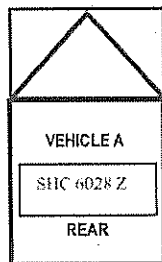

PREMIER TAXI

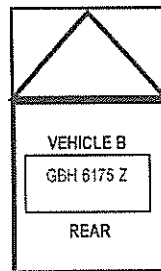

THIRD PARTY VEHICLE

 51284447/C

Driver's Signature & NRIC Number
Friday, February 01, 2019 @ 2:52:25 PM

(attended by)

REPUBLIC OF SINGAPORE DRIVING LICENCE



Licence Number: **S1289447C**
 Name: **TAN KHENG CHYE**
 Birth Date: **26 Feb 1958**
 Issue Date: **24 Jul 2003**

000680418D



Land Transport Authority

VOCATIONAL LICENCE



Licence No : **S1289447C**
 Name : **TAN KHENG CHYE**
 Issue Date : **1/12/2005**

Please visit www.lta.gov.sg to check the status of this vocational licence

REPUBLIC OF SINGAPORE
 IDENTITY CARD NO. **S1289447C**



Name

TAN KHENG CHYE

(HIRER)

9147 2698

OPTIMA K5



陳慶財

Race **CHINESE**
 Date of Birth **26-02-1958** Sex **M**
 Country of Birth **SINGAPORE**

YOU ARE LICENSED TO DRIVE VEHICLES IN THE FOLLOWING CLASS(ES)

Class	Description	PASS DATE
Class 2B	Motorcycles not exceeding 200 cc	23 Jun 1980
Class 3	Motor Cars and Motor Tractors the weight of which unladen does not exceed 2500 kilograms	28 Jul 1977

Licence No: **S1289447C**

NP 428A



This card is not transferable and is the property of the Land Transport Authority (LTA). It must be surrendered to the LTA on request. If found, please return to LTA, 10 Sin Ming Drive, Singapore 575701.

Type	Description	Issue Date
02	TAXI VL	13/12/1988



1529112



NRIC No. **S1289447C**



Blood Group **O+** Date of issue **20-12-1993**

Address
APT BLK 493D TAMPINES STREET 43
#08-324
SINGAPORE 1852



PREMIER AUTOMOTIVE SERVICES PTE LTD
OFFICE: 23 Changi South Avenue 2 #01-02 S(486443)
TEL: 65436676 / 65436689 FAX: 62141511
CO. REG NO.: 200707743D GST. REG. NO.: 200707743D

PREMIER TAXIS PTE LTD
23 CHANGI SOUTH AVENUE 2 #03-02
SINGAPORE 486443

TAX INVOICE

DATE 13-Mar-2019
PAGE 1 OF 1

ITEM	Description	QTY	U.PRICE	AMOUNT
	FINAL REPAIR BILL FOR KIA OPTIMA REGN NO: SHC 6028 X			\$ 830.00
TOTAL REPAIR COSTS AS RECOMMENDED BY SURVEYOR				\$ 830.00
GST @ 7%				\$ 58.10
GRAND TOTAL				\$ 888.10



for Premier Automotive Services Pte Ltd

(ALL THE REPAIR COSTS ARE SUBJECTED TO GST)

Text size + -

Enquire Transaction History**Transaction History Details**

Log Date/Time:	13 Jun 2014 / 09:23:40	Receipt No.:	AACCK001-AX239-140613-000013
Asset Type:	Vehicle	Transaction Amount:	\$70,018.00
Asset ID:	SHC6028X	Channel:	AA Counterless - CYCLE & CARRIAGE KIA PTE LTD
Transaction Type:	01.02 Register New Vehicle (AA)		
Business Transaction Reference No.:	20140613092340311539		
Vehicle No.:	SHC6028X		
Vehicle Type:	H10 - Public Transport Taxi (Motor Car)		
Vehicle Attachment 1:	Air-Con (Taxi)		
Vehicle Attachment 2:	-		
Vehicle Attachment 3:	-		
Vehicle Scheme:	Taxi (Company)		
First Registration Date:	13 Jun 2014		
Original Registration Date:	13 Jun 2014		
Vehicle Make:	KIA		
Vehicle Model:	OPTIMA 1.7(A) DIESEL		
Chassis No.:	KNAGM414ME5463556		
Engine No.:	D4FDDH307986		
Motor No.:	-		
Trailer Chassis No.:	-		
Propellant:	Diesel		
Passenger Capacity:	4		
Engine Capacity:	1685		
Power Rating:	-		
Unladen Weight:	1584		
Maximum Laden Weight:	2050		
Primary Color:	Silver		
Secondary Color:	-		
Manufacturing Year:	2013		
Open Market Value:	\$20,028.00		
Minimum PARF Benefit:	\$7,524.00		
PARF Eligibility:	Y		
No. of Transfer:	0		
Effective Ownership Date/Time:	13 Jun 2014 09:23:40		
COE No.:	2014061301001212R		
COE Expiry Date:	12 Jun 2022		
COE Bid Category:	-		
Actual QP/PQP Paid Amount:	\$57,338.00		
Lifespan Expiry Date:	12 Jun 2022		
Owner ID Type:	Company		

Certificate of Insurance

MOTOR VEHICLES (THIRD PARTY RISKS AND COMPENSATION) ACT (CHAPTER 189)
MOTOR VEHICLES (THIRD PARTY RISKS AND COMPENSATION) RULES, 1960
ROAD TRANSPORT ACT, 1987 (MALAYSIA)
MOTOR VEHICLES (THIRD PARTY RISKS) RULES, 1959 (MALAYSIA)

Certificate Number : 5095103893 **Cover** : Third Party

- 1. Index mark and Registration Number of Vehicle : **SHC6028X**
Chassis Number : KNAGM414ME5463556
- 2. Name of Policyholder : PREMIER TAXIS PTE. LTD.
- 3. Effective Date of Insurance : 20 Oct 2017
- 4. Expiry Date of Insurance : 31 Jan 2019
- 5. Persons or Classes of Persons entitled to drive*
 - (a) The Policyholder.
 - (b) Any licensed taxi driver driving on the Policyholder's order or with his/her permission.
Provided that the person driving is permitted in accordance with the licensing or other laws or regulations to drive the Motor Vehicle or has been so permitted and is not disqualified by order of a Court of Law or by reason of any enactment or regulation in that behalf from driving the Motor Vehicle.
- 6. Limitations as to Use*
 - (a) Use as a Taxi.
 - (b) Use for social domestic and pleasure purposes.

This Policy does not cover

- (a) Use for racing, pace-making, reliability trial or speed-testing.
- (b) Use whilst drawing a trailer except the towing (Other than for reward) of any one disabled mechanically propelled vehicle.

* Limitations rendered inoperative by Section 8 of the Motor Vehicle (Third- Party Risks and Compensation) Act (Chapter 189) and Section 95 of the Road Transport Act, 1987 (Malaysia), are not to be included under these headings.

EXCESS (SECTION I) : N/A
EXCESS (SECTION II) : S\$3,500
INSURE WITH COE : N/A
HIRE PURCHASE COMPANY : N/A
SUM INSURED : N/A

I/We hereby Certify that the Policy to which this Certificate relates is issued in accordance with the provisions of the Motor Vehicles (Third Party Risks and Compensation) Act (Chapter 189) and Part IV of the Road Transport Act, 1987 (Malaysia)

Agency : HL SUNTEK INSURANCE BROKERS PTE LTD (00000690672)
Date of Issue : 16 Oct 2017 17:13 hrs

For NTUC INCOME INSURANCE CO-OPERATIVE LIMITED

Countersigned By:



Authorised Officer



Chief Executive



08 February 2019

To Whom It May Concern

Dear Sir/Madam

CERTIFICATION LETTER

This letter serves to inform that Tan Kheng Chye of NRIC Number S1289447C is a registered driver of SHC6028X. Tan Kheng Chye is paying daily rental rate of \$102.72 (Inclusive of GST).

Should you require further information, please contact us at 6214 8880.

Thank you.

Yours sincerely

A handwritten signature in black ink, appearing to read "Kellie Poh".

Kellie Poh
Administration Manager

Prepared By: Hasnah

PREMIER TAXIS PTE LTD
23 Changi South Avenue 2
#03-02
Singapore 486443
Telephone: +65 6214 8880 Fax: +65 6214 0330
www.premiertaxi.com
Co. Reg. No. 200304975H



REPLACEMENT VEH GIVEN YES / NO

VEH NO. _____

JOB NO. _____

CHECK IN / OUT VOUCHER



DRIVER'S NAME TAN KHENG CHYE

NRIC S 1289447C HANDPHONE 91472698

TAXI REGN NO. S HC 6028 X MAKE / MODEL K02

DATE IN 250219 TIME IN 0930 DATE OUT 270219 TIME OUT 1425

KILOMETRES IN 404135 FUEL IN E 1/4 1/2 3/4 F
 KILOMETRES OUT _____ FUEL OUT E 1/4 1/2 3/4 F

INDICATE AREA OF DAMAGE HERE:

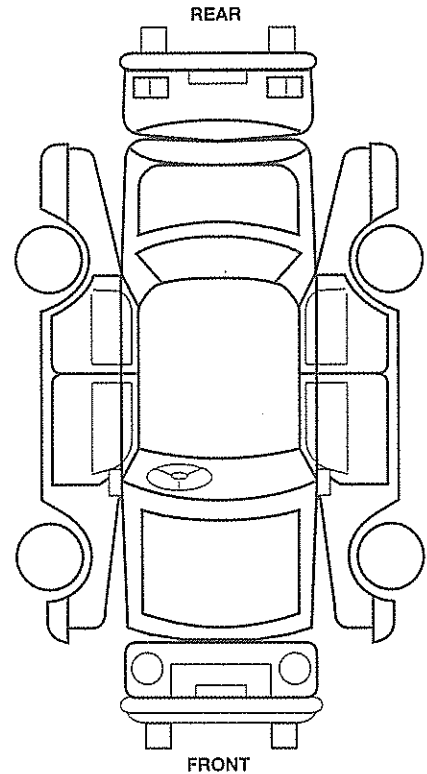

BODY MARKINGS

- 1 - Light Dent
- 2 - Serious Dent
- 3 - Light Scratch
- 4 - Serious Scratch
- 5 - Damaged
- 6 - Chip
- 7 - Crack
- 8 - Peeling

TAXI METER DOWNLOADED

YES | **NO**

DATE / TIME TOWED IN TO WORKSHOP
D D M Y Y H H M M

DATE / TIME CALL TO DRIVER FOR VEHICLE COLLECTION
D D M Y Y H H M M

I ACKNOWLEDGE AND CONFIRM THAT I HAVE EXAMINED THE ABOVE SAID VEHICLE AND THAT THE SAME IS IN GOOD CONDITION AND TO MY SATISFACTION IN EVERY RESPECT TOGETHER WITH THE ACCESSORIES / ITEMS LIST ABOVE. THIS VOUCHER IS USED IN CONJUNCTION WITH THE TERM RENTAL AGREEMENT.

CHECK IN	CHECK OUT
<u>Tan Kheng Chye</u> X	<u>Tan Kheng Chye</u> X
DRIVER'S NAME	DRIVER'S NAME <u>Tan K</u>
<u>[Signature]</u> X	<u>[Signature]</u> X
DRIVER'S SIGNATURE / DATE / TIME	DRIVER'S SIGNATURE / DATE / TIME
<u>[Signature]</u>	<u>[Signature]</u>
CHECKED IN BY (PREMIER'S AUTHORISED WORKSHOP)	CHECKED OUT BY (PREMIER'S AUTHORISED WORKSHOP)

SERVICE / REPAIRS DONE	DRIVER'S REMARKS
<input type="checkbox"/> SERVICING <input type="checkbox"/> OTHERS: <input type="checkbox"/> T / BELT <input type="checkbox"/> AIRCON SYSTEM <input checked="" type="checkbox"/> ACCIDENT: DATE / TIME of ACCIDENT: <input type="checkbox"/> TURBO D D M Y Y H H M M <input type="checkbox"/> BRAKE SYSTEM <input type="checkbox"/> CLUTCH SYSTEM <input type="checkbox"/> BULB <input type="checkbox"/> UNDER CARRIAGE <input type="checkbox"/> CPF <input type="checkbox"/> BATTERY	
TP / V	



RECORDS MANAGEMENT CENTRE

**GENERAL INSURANCE ASSOCIATION OF SINGAPORE
RECORDS MANAGEMENT CENTRE**

6 Raffles Quay #18-00, Singapore 048580

Phone: +65 6224 0010 Fax: +65 6224 0030

Operating Hours: Monday to Friday 9am to 5pm

GST Registration No: M400017735

Third Party Insurer Enquiry

Our Ref No: GR-19-018530

Date of Request: 01/02/2019

Your Ref No: Online Purchase

Premier Automotive Services Pte Ltd
23 Changi South Ave 2
#01-02
Singapore 486443

Dear Sir/Madam,

Enquiry Date 01/02/2019
Enquiry By VINCENT CHUA WEE AN
TP Vehicle No. GBH6175Z
Accident Date 01/02/2019

Enquiry Result

TP Vehicle No.	Insurer	Period of Insurance	Insurer Tel. No.
GBH6175Z	Lonpac Insurance Bhd	31/07/2018-30/07/2019	+65 62507388

Thank You.

The images provided to you are taken from the original reports forwarded to the centre by the members of the General Insurance Association of Singapore and we take no responsibility for their accuracy or contents and shall be under no liability whatsoever for any loss or damage arising out of or in connection with the reports or their images.

This is a computer generated document and requires no signature.



**GENERAL INSURANCE ASSOCIATION OF SINGAPORE
RECORDS MANAGEMENT CENTRE**
6 Raffles Quay #18-00, Singapore 048580
Phone: +65 6224 0010 Fax: +65 6224 0030
Operating Hours: Monday to Friday 9am to 5pm
GST Registration No: M400017735

TAX INVOICE

Our Ref No: GR-19-018530
Date of Request: 01/02/2019

Your Ref No: Online Purchase

Premier Automotive Services Pte Ltd
23 Changi South Ave 2
#01-02
Singapore 486443

Dear Sir/Madam,

Enquiry Date 01/02/2019
Enquiry By VINCENT CHUA WEE AN
TP Vehicle No. GBH6175Z
Accident Date 01/02/2019

DESCRIPTION	AMOUNT (S\$)
TP Insurer Enquiry	1.87
GST Amount	0.13
Total Amount Due (GST Inclusive)	2.00

Thank You.

This is a computer generated document and requires no signature.

For GIARMC Official use:

Date:

GIRO Cash Cheque